

ACTUATORS & DAMPERS

WHISKER SWITCH KLNJ-A2



DESCRIPTION

The KLNJ-A2 whisker switch is a high-quality, multi-directional contact switch with a plastic coated spring-rod whisker. It is perfect for sensing damper blade position and can be used to provide position status of valve linkages or other mechanical devices.

FEATURES

- Plastic coated spring-rod whisker for long life
- Captive wiring cover screws to save time
- Heavy duty 10A @ 120 VAC contacts



KLNJ-A2



1
ACTUATORS & DAMPERS

SPECIFICATIONS	
Contact Rating	10A @ 24 VAC, 10A @ 120 VAC, 6A @ 24 VDC
Contact Type	1 N.O. and 1 N.C.
Wiring Terminations	Screw terminals
Conduit Connection	1/2" NPT
Switch Angle	15° make, 6° reset
Operating Temperature	-13° to 131°F (-25° to 55°C)
Enclosure Rating	IP67
Dimensions	8.0"H x 1.6"W x 1.7"D (20 x 4.0 x 4.2 cm)
Weight	0.5 lb (0.2 Kg)
Approvals	CE, UL File #E117960
Warranty	1 year

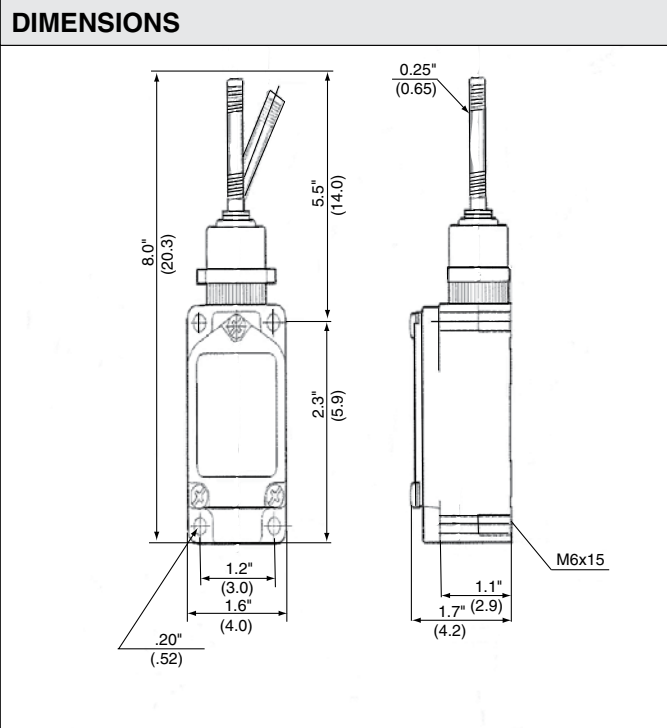

ORDERING INFORMATION

MODEL	DESCRIPTION
KLNJ-A2	Whisker switch with coated spring-rod and 10A @ 120 VAC contacts